

Manual

Ultrasonic Sludge Level Analyzer



Catalogue

I Product profile.	03
1.1 preamble.....	03
1.2 Product characteristics.....	03
1.3 principles of measurement.....	04
1.4 Technical parameters.....	05
1.5 areas of application.....	05
II Debug and install.	06
2.1 Keyboard input.....	06
2.2 instrument connection.....	07
2.3 installation of instruments.....	08
III Menu list	10
IV Relay output settin.	19
V Trouble shooting.	19
Manufacturer Certificate.	21
Guarantee log.	22

I Product profile

1.1 introduction

Ultrasonic mud-water interface instrument is an intelligent ultrasonic instrument which has been developed and produced independently by our company for many years. After continuous learning and innovation, combined with the actual needs of customers and the development of new ultrasonic measurement products. This product adopts modular circuit design, military quality multi-layer PCB board, hardware structure tight, reasonable layout. Other functions, RS-485 module and current output module can also be added according to customer's needs, which can better match PLC and other control instruments. This product uses the import industrial grade chip, the digital temperature compensation and so on ... Relevant ASIC. Strong anti-interference, can set the upper and lower limit arbitrarily Node and on-line output adjustment with on-site display.

The working principle is to use the transducer to make ultrasonic waves in the water, and when the sound waves meet obstacles and reflect back to the transducers, according to the time of the round trip of the sound waves and the propagation speed of the sound waves in the measured waters, The distance between the obstacle and the transducer can be obtained.

When the channel height H is known, the height h of the bottom sludge to the bottom of the canal can be calculated. The mud-water interface instrument is displayed by large-screen Chinese graphic LCD, and the distance D and sludge height h (after setting H) can be displayed.

The mud water interface meter can measure the depth of water quickly and accurately in the course of ship navigation. It is often used in waterway survey, bottom topography survey, sea channel survey and ship navigation and positioning, etc.

1.2 Characteristics of ultrasonic mud-water interface instrument

(1) the probe has the advantages of low power consumption, simple installation, easy positioning, wide application conditions, output standard 4-20mA current signal, and can be used as a liquid level meter alone.

(2) according to the operating conditions, the probe can be selected IP68,

anticorrosion, explosion-proof, small blind zone, ultra-low power consumption, large range and other special products.

(3) Chinese display interface, 16 key button operation. More easy to understand menu options, more rapid realization of man-machine communication.

(4) backup and restore setting parameters.

(5) many kinds of physical quantities can be measured.

(6) it has the function of digital filtering and echo recognition, and can set the fixed interference filtering function manually.

(7) HART protocol communication support is added to the upgraded version, which makes up for the disadvantage of two-wire instrument without data output, and can communicate directly with HART field instrument.

(8) support MiniSD card data acquisition, support wireless transmission, support micro printer. (order selection)

1.3 measuring principle

The principle of the ultrasonic mud-water interface instrument is to make use of the transducer to send out the ultrasonic wave in the water, when the sound wave meets the obstacle and reflects back to the transducer, according to the time of the sound wave going back and forth and the velocity of the sound wave propagation in the measured water area, The distance between the obstacle and the transducer can be obtained. When the channel height H is known, the height h of the bottom sludge to the bottom of the canal can be calculated. The mud-water interface instrument is displayed by large-screen Chinese graphic LCD, and the distance D and sludge height h (after setting H) can be displayed. By measuring the time difference between transmitting and receiving, the measuring distance is calculated according to the propagation velocity of sound wave in air. Its measurement formula is as follows:

$$D = V * T / 2$$

D: measured range

V: The speed at which sound waves travel through liquids.

T : The time when sound waves travel in liquids.

The mud water interface meter can measure the depth of water quickly and accurately in the course of ship navigation. It is often used in waterway survey,

bottom topography survey, sea channel survey and ship navigation and positioning, etc.

1.4 technical parameter

- (1) range: 5m, 10m (order selected)
- (2) Blind areas: < 0.5m-0.8m (different from measurement range)
- (3) ranging accuracy: $\pm 0.3\%F.S$
- (4) display: Chinese 3-inch LCD
- (5) liquid level resolution: 1mm
- (6) Keyboard: 16-bit keyboard operation
- (7) signal output(optional): 4~20mA(standard), 0~ 20mA, 1~ 5 V, 0 ~5 V, RS485, Hart protocol, 4-channel relay output (relay contact capacity: AC:5A 250V DC:10A 120V)
- (8) operating voltage: AC220V or DC12~24V
- (9) Power consumption: <8W
- (10) Meter material: host material ABS, Sensor material: stainless Steel
- (11) Host form factor: 240mm×184mm×110mm
- (12) Sensor dimensions: $\Phi 68\text{mm}\times 57\text{mm}$ (different from measurement range)
- (13) Sensor mounting interface: G1 / 2
- (14) Sensor cable: 10m shielded cabl
- (15) working environment: normal temperature, atmospheric pressure
- (16) Protection level: host Protection level IP60

Sensor protection level IP68

1.5 application area

Ultrasonic mud-water interface instrument is widely used in rivers, water and sewage treatment, water supply, electricity, mines, factories, urban sewerage channels, control systems and other related fields.

II Debug and install

2.1 keyboard entry

Before the measurement starts, just complete the installation according to the request, carry on the basic parameter setting, can power up to carry on the normal measurement.

Key 18 keypad input, press the key basic function as shown in Table 1,
press the key as shown in figure 2-1

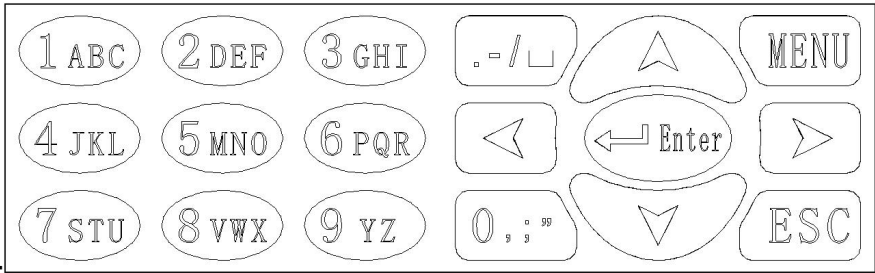



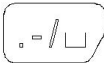





Figure 2-1

Table I

	menu return	Keystroke entry password input		canc el	Return to the previous level
	left shift Moving key	cursor left		symp ol	incoming symbol
	right shift Moving key	cursor right		'0'	'0' input key
	Confirm Preservation	OK, Save in menu		high and low select	Select menu up and Down

2.2 Instrument connection

The current is isolated and the "AO-" is the current output port. By default, there is only the first current output, that is, the AO1 output.



图 2-2

Note: please connect correctly according to the wire connection definition, so as not to cause abnormal operation and damage of the instrument due to the wrong connection.

2.3 Instrument installation

2.3.1 Sensor mounting height

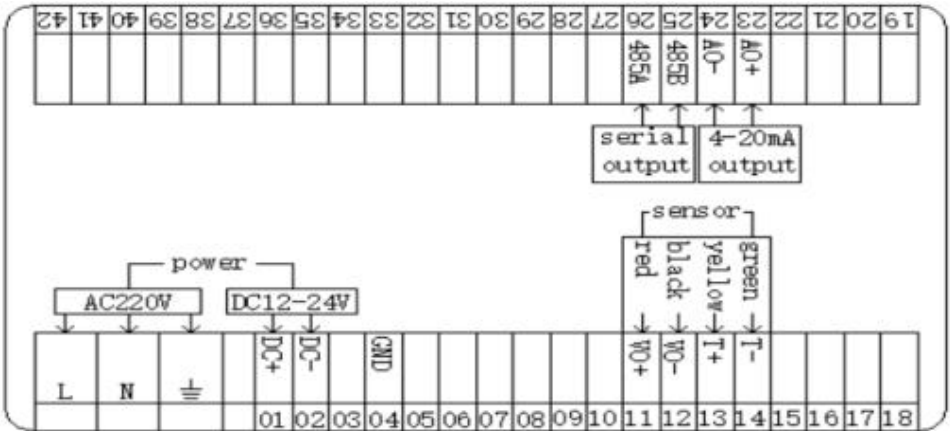
When the probe is installed, ensure that the probe is always below the minimum water level of 20cm. And ensure that the distance from the probe to the highest mud surface is greater than the blind area.

2.3.2 Host installation

Mainframe has embedded and wall hanging two kinds of installation methods.(1)

Host form factor: 180mm*160mm*76mm, As shown in figure 2-3, 2-4:

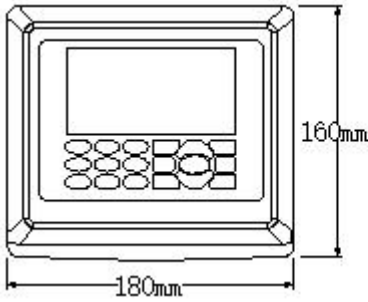

Figure 2-3

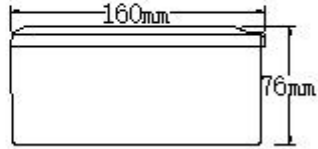

Figure 2-4

(2) Embedded installation

Built-in mounting aperture dimensions 168mm*130mm , As shown in figure 2-5, 2-6:

(3) Wall mount

There are four quick wall mounting holes in the product design, which only need to be fixed according to the wall point.

Then hang up the product. Wall-hanging hole distance is 167mm*105mm , As shown in figure 2-7:

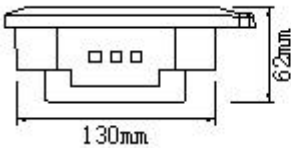

Figure 2-5

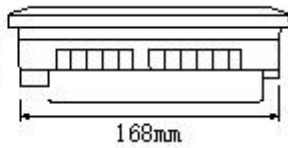

Figure 2 - 6

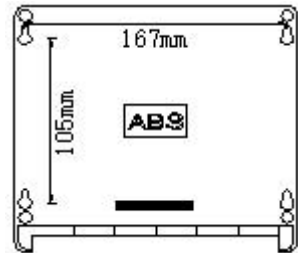

Figure 2 - 7

2.3.3 Installation attention

Considerations for the use of sensor probes:

- 1、 The sensor probe must be installed vertically with the water surface.
- 2、 there should be no other solid shielding between the sensor probe and the

bottom of the pool, otherwise there will be interference signals.

3、 the sensor probe should be protected from the impact of floating material in water. If the suspended substance in water is easily attached to the probe surface, it is recommended to install a self-cleaning system to keep the probe surface clean.

4、 the sensor probe immersion depth is recommended as about 20cm (this distance can be increased or decreased depending on the speed of river flow), and the probe distance from the pool wall is at least 50cm (this distance can be increased according to the measured depth and the unevenness of the pool wall).

5、 the sensor probe is measured in the shallow water area, and the underwater riverbed environment has a certain degree of slope, the sensor probe as far as possible perpendicular to the underwater riverbed reflector.

Sensor probe and accessories installation instructions: 1, two long 30cm standard stainless steel pipe and wire are threaded to connect the stainless steel pipe and the sensor probe interface. Sensor probe

The head has been fitted with a deflector (anti-collision block) at the factory.

If a switching power supply is used to supply DC, the DC power supply must be negatively connected to the earth. Installation wiring please refer to manual or level meter body label, in order to ensure the stability of this machine, analog output accuracy, please power on before normal use > 15 minutes preheating. When the ultrasonic sensor is installed, the product should be debugged and then fixed. In order to prolong the instrument service life, should do well instrument sunscreen waterproof measure. When working in the field, put a sunshade over the meter to avoid direct sunlight and rain. Lightning protection measures should be taken for field use.

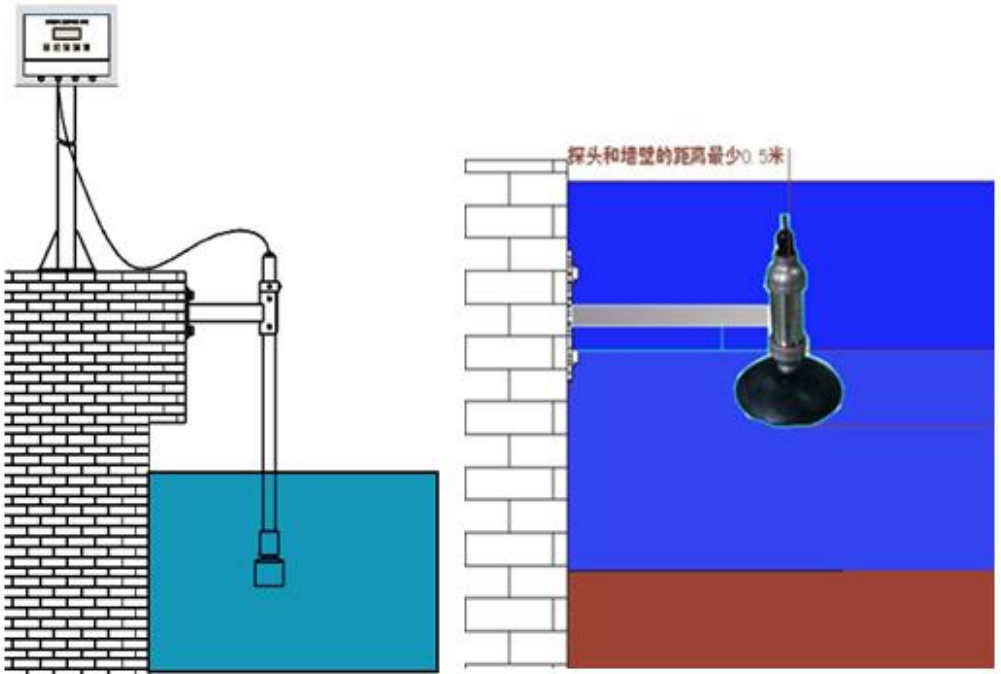

III Menu list

3.1 Type I split ultrasonic liquid level meter commonly used parameter menu list, check the password "0000",

See schedule 1 for a detailed menu list.

1 st Menu	2 nd Menu	3 rd Menu	4 th Menu	5 th Menu	Note
Login					
State	/Battery Voltage				
	Value	CH1			No modify
		...			No modify
		CH32			No modify
	NetSignal				
Analog		CH1			No modify

		CH2			No modify
	Relay	CH1			No modify
		...			No modify
		CH4			No modify
	Pulse Value				
Last power-off time					
Communication	Write Protect				
	Address				
	Port	Input	Baud Rate		No modify
			Parity		No modify
			Delay		No modify
		Output	Baud Rate		
			Parity		
			Delay		
		Other	Baud Rate		
			Parity		
			Delay		
	Protocol	Modbus Host	Port		
			Read Command		
			Write Command		
			Save Command		
		Custom	Port		
			Auto Send Time		
			Offline Save		
Send					
Receive					
Delete Offline Data					

		Modbus Slave	Port		
			Offset		
			Data Array		
			Data Type		
			Data Zoom		
		AT Protocol	Port		
		HART Protocol	Port		
		Network	Information		
			ServerA	Address	
				Port	
				Type	
			ServerB	Address	
				Port	
				Type	
			Time Sync Server		
			Register ID		
			Register Data		
			Heart Data		
			Heart Time		
			Reset Number		
Monitor	Input				
	Output				
	Other				
Install	Variable	Global	Name		
			Unit		

			Decimal		
			Overrun		
		Group1	Number		No modify
			Name		
			Unit		
			Decimal		
			Calibration	Zero	Adjustable
				Linear	No modify
		...	as above		
		Group8	Number		No modify
			Name		
			Unit		
			Decimal		
			Calibration	Zero	Adjustable
				Linear	No modify
	Custom	Name			
		Unit			
		Formula			
	Analog	CH1	Number		No modify
			Type		No modify
			Linear	Damp	
				Zero	No modify
				Range	No modify
				Zero Scale	Adjustable
				Range Scale	Adjustable
			Logic	False	
				True	
Pulse Count			Damp		
			Minimum Cycle		

				Threshold		
				Ratio		
				Flow Clear		
			Pulse Frequency	Damp		
				Minimum Cycle		
				Threshold		
				Coefficient A		
			Coefficient B			
			CH2	As CH1	As CH1	As CH1
			Subsection Calibration			
	Digital	Cycle				
		Timeout				
		Again				
		CH1	Number		No modify	
			Address		No modify	
Total						
Command						
Data Type						
Data Size						
...	As CH1		As above			
CH8	As CH1		As above			
Config File Read						

	Flow Calculation	Variable	Level Number		No modify	
			Speed Number		No modify	
			RealTime Flow		No modify	
			Total Flow		No modify	
			Other			
		Max Flow				
		Flume Type				
		Level Method	Parshall	Flume Number		
				Parameter C		No modify
				Parameter N		No modify
	Low				No modify	
	High				No modify	
	Rectangular		Weir			
			Width			
			Height			
	Trapezium		Width			
	BroadCrested		Width			
		Length				
		Height				
	Speed Method	Trapezium	Width			
Slope Gradient						
	Circle	Diameter				

			U Shape	Width		
				Arc Height		
		Limit	Low		No modify	
			High		No modify	
			Speed Level Ratio		No modify	
Formula						
Flow Clear						
Output	Analog	CH1	Number		No modify	
			Zero			
			Range			
			Zero Scale		Adjustable	
			Range Scale		Adjustable	
			Virtual			
	CH2	As CH1		As above		
	Relay	CH1	Number			
			Main Parameter			
			Slave Parameter			
			Mode			
			Set to			
			...	As CH1		
			CH4	As CH1		
			Multivariable	CH1		
	Pulse/Switch		Number			
			Ratio			
Maximum Frequency						
Pulse Value						
Storage	Disk Management	Volume				
		Free				
		Format		No modify		

	Timing Record	Alarm	Number		
			Type		
			Low		
			High		
			State		
		Cycle			
		Maximum Size			
		Format			
		File Type			
		Path			
	Delete				
	Statistic	Mode			
		Data Definition			
		File Type			
		Maximum Size	Hours		
			Date		
			Week		
			Month		
			Year		
		Path			
Subpath		Hours			
		Date			
		Week			
		Month			
		Year			
Delete					
Statistic	Mode				
File View					
System	Language				
	Date				
	Time				
	Display	Contrast			

		Close Screen Delay			
		Name			
		Interface Config			
	User	User Password			
		Admin Password			
		Engineer Password			
	Backup	Recovery			
		Backup			
		Import			
		Export			
	Other	RTC Prescaler			
		RTC Calibration(S/30 D)			
		Voltage Amend			
		Start Delay			
	About	Type			
		Version			
Update Date					
Update Time					
Device ID					
Copyright					

IV Relay output settin

This instrument has 4 relays output. When uses relay control, it must be set control point: D and H. D for relay start point, H for relay end point. X for display value. It works as follows:

When D<H

X<D close	D	D<X<H retain	H	X>H Disconnect
-----------	---	--------------	---	----------------

When D>H

X>D close	D	D>X>H retain	H	X<H Disconnect
-----------	---	--------------	---	----------------

V Trouble shooting

No.	problem	probable reason	remedy
1	Not working when power on, no display, no sound of sensor	① power is not connected or "+" "-" polarities are connected reversely; ② too low voltage resulting no working or too high resulting damage	① check to ensure correct wiring as instructed. ② use DC supply, contact with distributor
2	No display of sensor but with sound	① operation of turning off display has been carried out. ② connected to high voltage, damaging display chip	① press any key to turn on display; ② contact with distributor.
3	With sound and display, but the values not change with distance	① too low input voltage leading to abnormal instrument. ② the sensor or power driver damaged.	① use DC supply ② contact with distributor
4	With display and sound, no change with distance or irregular fluctuation of values	① too deflective installation ② improper setting of pulse intensity, leading to great residual vibration or diffraction ③ more than 2 instruments on stream, interfering each other ④ too much electromagnetic disturbance in working area	① adjust the axis of sensor vertical to surface to be measured ② adjustment transmit intensity ③ try to eliminate interference; ④ find out disturbance source and shield

			from it.
5	With sound of sensor, display: no sensor	① exceeding measure range ② too close between surface and sensor ③improperly used for high dust, foam or steam content fields, or too high or too low working temperature; improper setting of pulse intensity	① adjust actual range with permitted ② adjust working conditions as required ③ change transmitting intensity until stable display
6	With sound of sensor, display deviations exceeding 10cm	①non vertical installation, leading to multiple reflection ②installed too close to wall, sonic wave reflected midway ③ check for correct setting of E ④check for correct display of temperature	①adjust installation positions several times. ② correctly set sensor depth in water ③ for large temperature difference, adjust "CB" to proper value.
7	4-20mA output too high or low, fluctuating	①too large load resistance ②FS be changed, or other parameters be changed ③undesired supply rectification and filtering	①lower load resistance ②readjust parameters③ replace with DC regulated supply with larger capacity
8	Serial port incommunicable	①reverse connecting of A and B ports ②wrong serial port parameter	① change wiring, reset para., same with those of main unit
9	Output control not activated	①wrong para. Setting ②external current-limiting resistor too large ③external current-limiting resistor too small, damaging the instrument	1、 reset para. ②decrease current-limiting resistor ③ contact with distributor

Manufacturer Certificate

Sense range: FS= ____m

Unusable area: 800mm; 600mm; ≤60mm; other

Accuracy: ±0.3%×max range; ±2mm; other

Display Resolution: 1mm

Output: 0-20mA; 4-20mA; 0-5V; 1-5V; 0-10V;

1-10V; RS485; Relays

Working temperature: normal; -10-60°C; other

Working pressure: normal; other

Working humidity: ≤80%RH

Storage temperature: -40-85 Deg. C

Storage humidity: ≤70%RH

Working voltage: 220V AC ro 12~24V DC

Normal power consumption: <8W

Guarantee log

Purchaser		Telephone	
Address		Post code	
Product		Type	
Item No.		Delivery date	
Repair record			
Notes	<ol style="list-style-type: none"> 1. According to THREE GUARANTEES, When there are problems with the product under correct operation, it can be refunded, changed and repaired free of charge within one week, three months and one year respectively from the day it was bought. 2. For the problems caused by improper use, only the cost of material will be charged. 3. The product can not be dismantled or unsealed without manufacturer's agreement; otherwise the repair service is not available. 4. The freight out and home in relation to repair will be paid by customer. 		

